

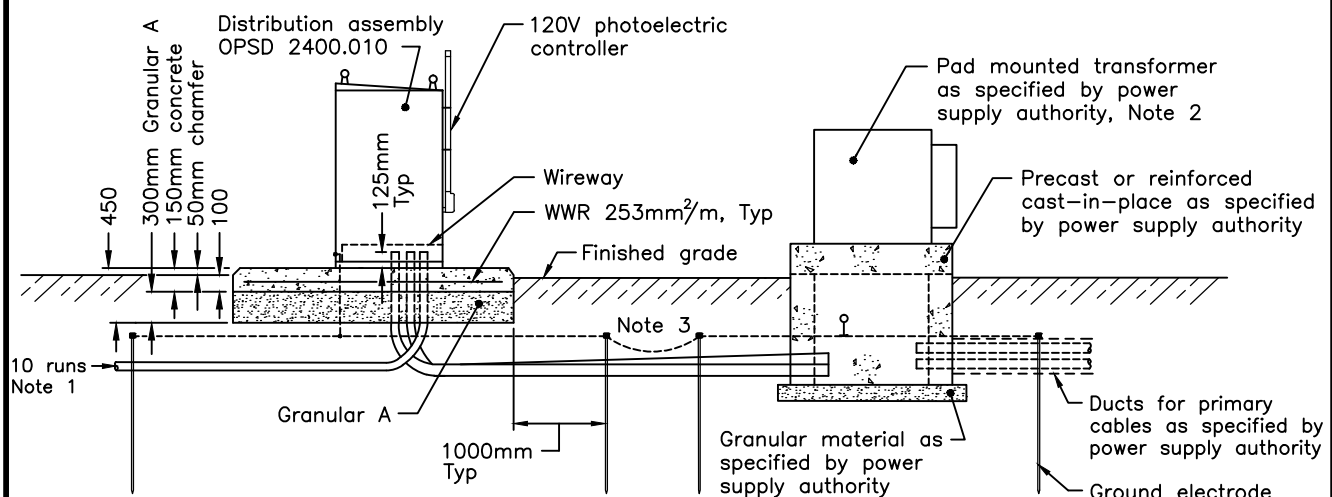

PLAN



SECTION A-A

- NOTES:**
- 1 Orientation of ducts as specified.
 - 2 Installation and grounding details shall be as specified by power supply authority.
 - 3 Transformer pads located within 15m from the distribution assembly shall have grounding system bonded to the grounding grid of the distribution assembly.
 - 4 Space between ducts shall be 50mm minimum.
 - 5 All spare ducts shall be extended 1500mm and capped.
 - 6 Dimension of concrete pad to suit distribution assembly enclosure.
- A This OPSD shall be read in conjunction with OPSD 2126.020 and 2400.030.
 B All dimensions are in millimetres unless otherwise shown.

ONTARIO PROVINCIAL STANDARD DRAWING		Nov 2018	Rev 3	
DISTRIBUTION ASSEMBLY				
CONCRETE PAD AND DUCTS PLAN AND SECTION A-A				
OPSD 2126.010				