

NOTES

1. A DRAIN PIPE CONNECTION FROM THE CHAMBER TO A STORM SEWER SHALL BE PROVIDED IF SPECIFIED ON THE CONTRACT DRAWINGS.

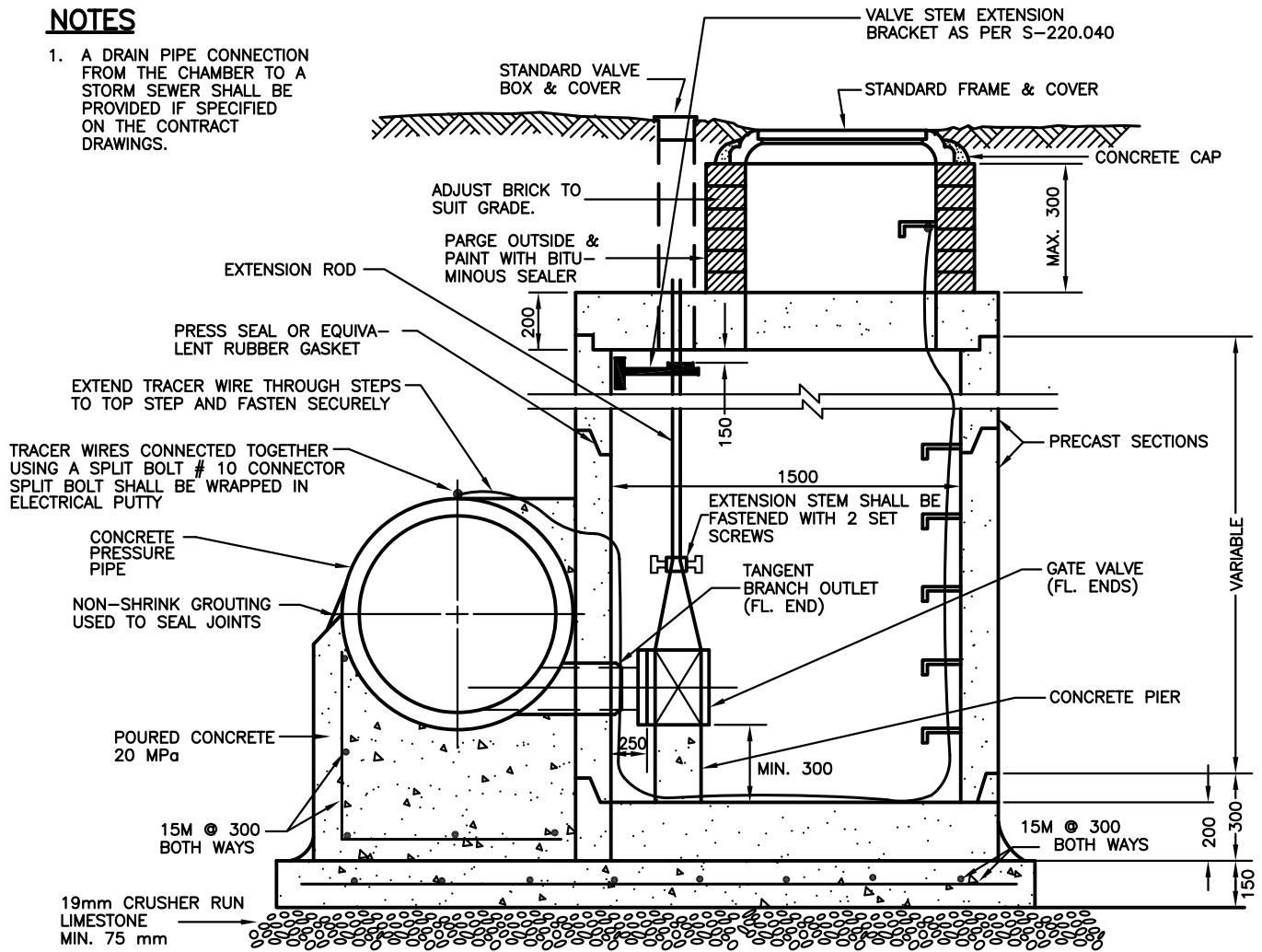

ALL DIMENSIONS IN MILLIMETRES EXCEPT WHERE NOTED.



WORKS DEPARTMENT

DRAIN VALVE IN CHAMBER
100 mm, 150 mm, AND 200 mm

DWG. DATE: 1978 03
 REVISION NO.: 9
 REV. DATE: 2013 04
 SCALE: N.T.S.

S-220.060