

DOWEL CONNECTION WITH EXPANSION JOINT
TYPE I

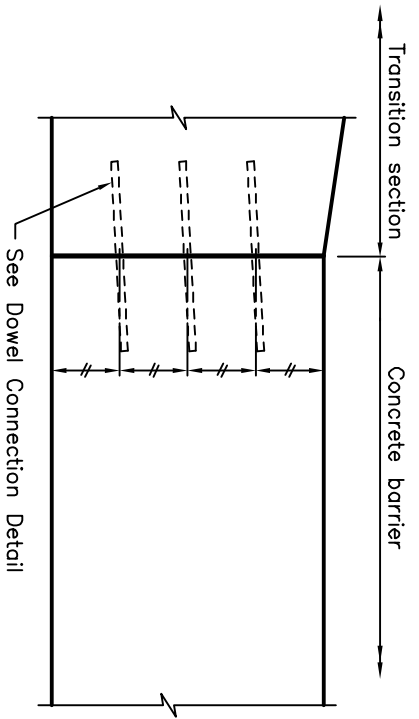

DOWEL CONNECTION WITHOUT EXPANSION JOINT
TYPE II

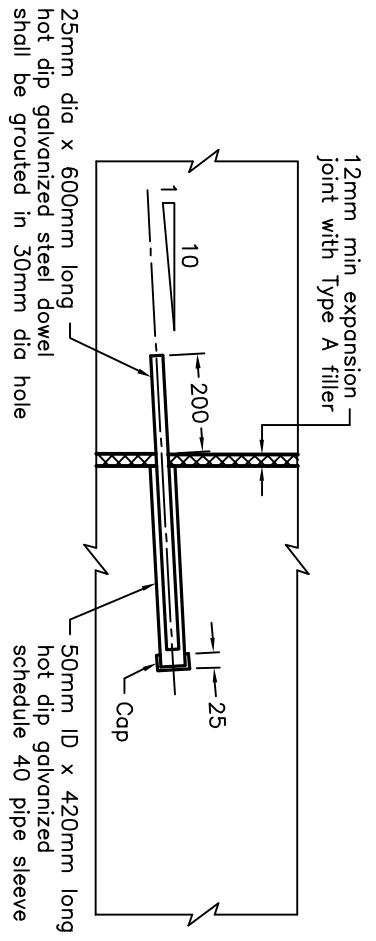

DOWEL CONNECTION DETAIL
TYPE I

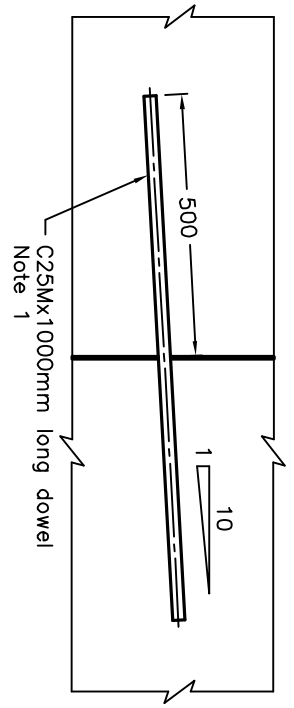

DOWEL CONNECTION DETAIL
TYPE II

NOTES:

- 1 Dowel shall be placed along centreline of transition section.
- A This OPSP shall be read in conjunction with OPSP 911.381.
- B All dowels shall be hot dip galvanized according to ASTM A123.
- C All dimensions are in millimetres unless otherwise shown.

ONTARIO PROVINCIAL STANDARD DRAWING		Nov 2015	Rev 1
GUIDE RAIL SYSTEM, CONCRETE BARRIER		-----	

DOWEL CONNECTION DETAIL		OPSP 911.382	

