

H BEAM BASE DETAIL

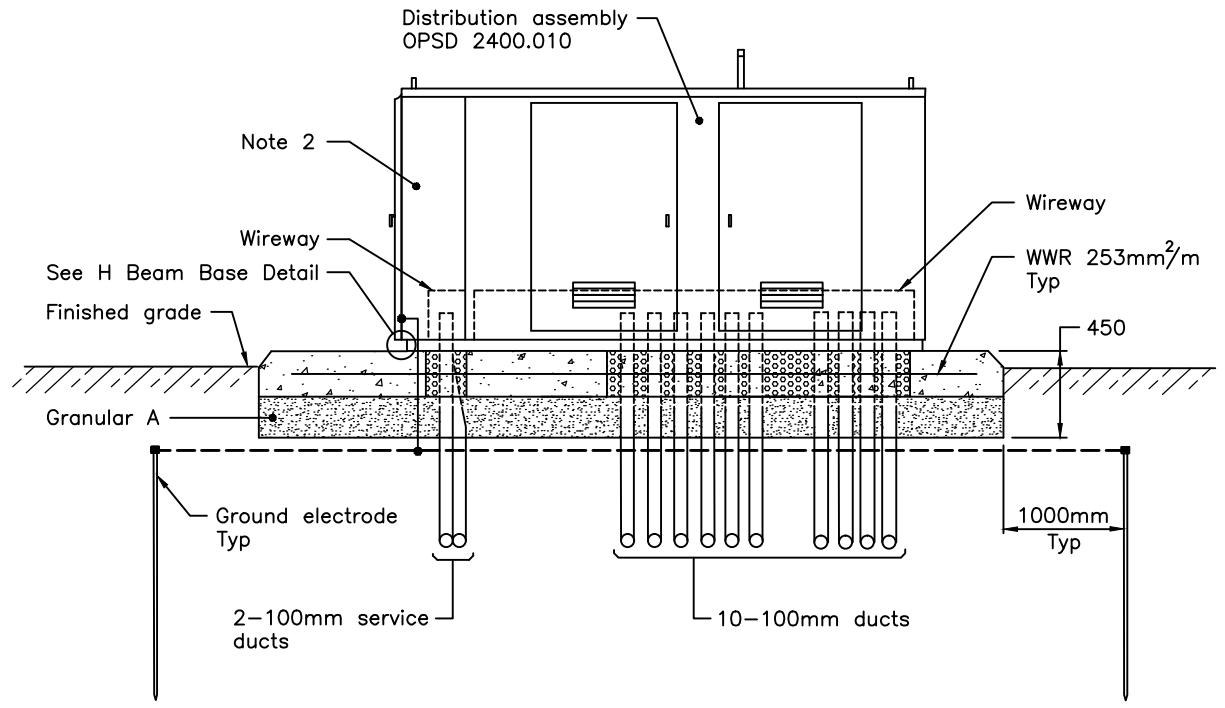

SECTION B-B

NOTES:

- 1 Anchor bolts shall be installed on exterior face of base beam.
- 2 Metering compartment as specified by power supply authority.
Metering compartment may be a separate stand-alone enclosure.
- A For plan view see OPSPD 2126.010.
- B All dimensions are in millimetres unless otherwise shown.

ONTARIO PROVINCIAL STANDARD DRAWING		Nov 2018	Rev	3	
DISTRIBUTION ASSEMBLY					
CONCRETE PAD AND DUCTS SECTION B-B					
OPSD 2126.020					