

Tapered top
See alternatives B
and C

Riser sections
as required

Transition slab

Riser sections
as required

Bench or sump
as specified
Note 1

Precast slab base
See alternative A

Granular
bedding

ALTERNATIVES

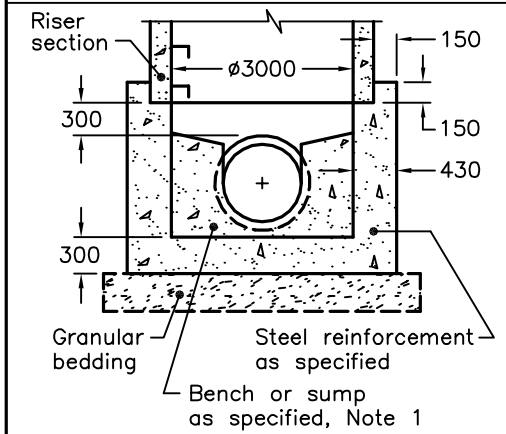

A CAST-IN-PLACE BASE

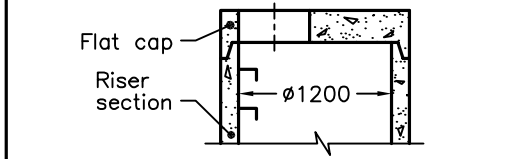

B 1200mm PRECAST FLAT CAP

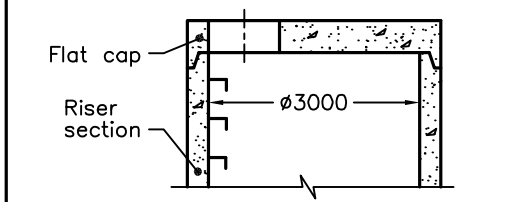

C 3000mm PRECAST FLAT CAP

NOTES:

- 1 For sump detail, see OPSD 701.010.
- A Granular backfill shall be placed to a minimum thickness of 300mm all around the maintenance hole.
- B Precast concrete components shall be according to OPSD 701.030, 701.031, 701.070, 701.071, 703.014, 703.024, 706.040 and 706.041.
- C Structures exceeding 5.0m in depth shall include safety platform according to OPSD 404.020.

- D Pipe support shall be according to OPSD 708.020.
- E For benching and pipe opening details, see OPSD 701.021.
- F For adjustment unit and frame installation, see OPSD 704.010.
- G All dimensions are nominal.
- H All dimensions are in millimetres unless otherwise shown.

ONTARIO PROVINCIAL STANDARD DRAWING	Nov 2014	Rev 4	
PRECAST CONCRETE MAINTENANCE HOLE	-----		
3000mm DIAMETER	OPSD 701.014		