

**CONTRACTION JOINT WITHOUT DOWEL BAR**

**CONTRACTION JOINT**

**EXPANSION JOINT**

**CONSTRUCTION JOINT**

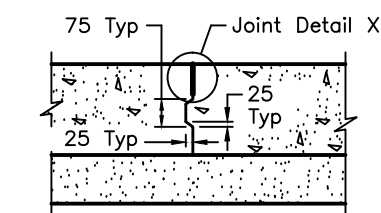

**LONGITUDINAL KEYWAY JOINT WITHOUT TIE BAR**

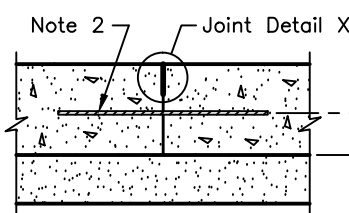

**LONGITUDINAL JOINT SINGLE LANE PAVING**

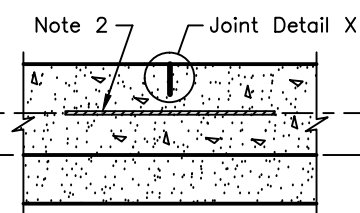

**LONGITUDINAL JOINT MULTI-LANE PAVING**

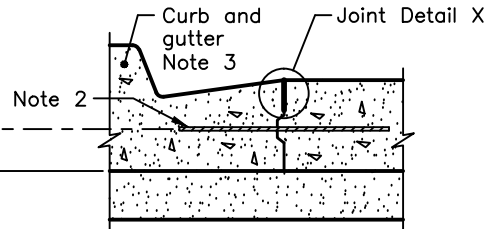

**LONGITUDINAL JOINT CONCRETE SLAB ADJACENT TO CURB WITH GUTTER**

**NOTES:**

- 1 Field cut 20mm thick expansion joint filler material, the width of pavement plus shoulder and depth of concrete slab less the depth of reservoir.
  - 2 Use 15x760mm epoxy coated deformed tie bars spaced at 600mm OC at 0.57.
  - 3 Depth of curb and gutter shall be extended to coincide with bottom of concrete slab.
- A Paving width shall not exceed 4.5m without a longitudinal joint. Where paving width is greater than 4.5m, the longitudinal joints shall be located at the lane delineations.
- B All dimensions are in millimetres unless otherwise shown.

**LEGEND:**

T - Concrete slab thickness

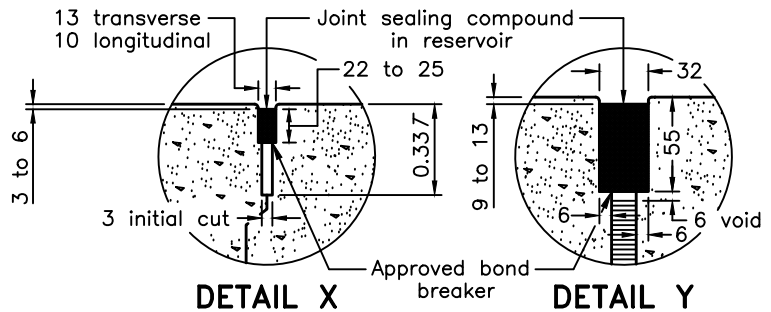

**JOINT DETAILS RESERVOIR CUT TYPE**

ONTARIO PROVINCIAL STANDARD DRAWING	Nov 2017	Rev 2	
<b>CONCRETE PAVEMENT JOINT DETAILS</b>			
<b>OPSD 552.010</b>			