

SECTION B-B

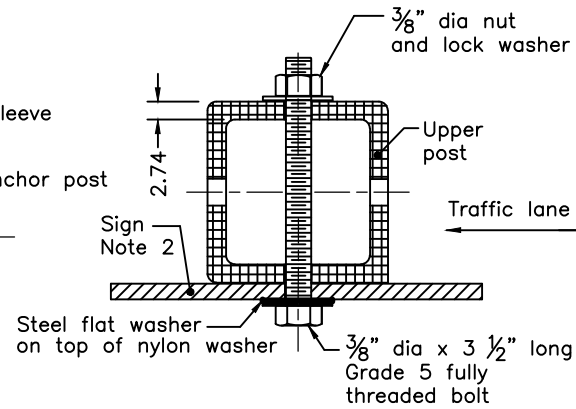

SECTION A-A

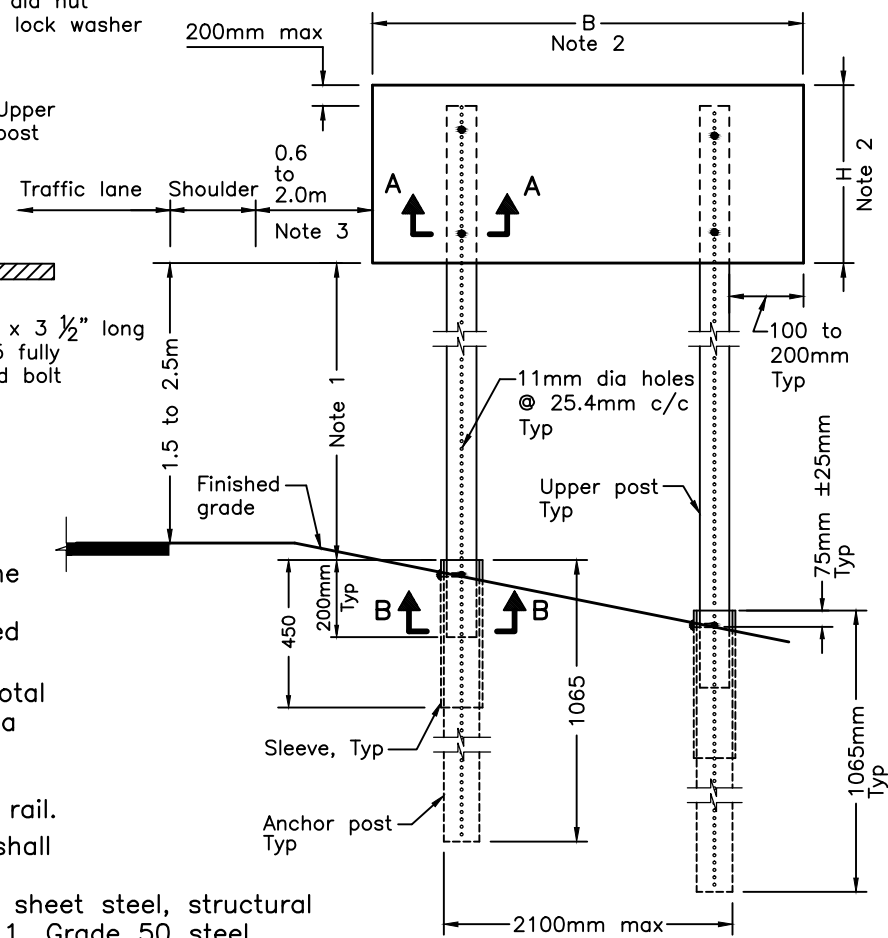

FRONT

NOTES:

- 1 Minimum vertical clearance of 2.1m shall be provided between the finished grade and the bottom of the lowest sign or tab.
- 2 This support system shall accommodate sign board sizes specified in the Contract Documents for a sign width (B) from 90cm to 240cm, up to a maximum sign height (H) of 150cm, and the total sign area including tabs shall not exceed the maximum sign area of 3.15 square metres.
- 3 When curb is present, minimum 0.3m from face of the curb. When guide rail is present, minimum 1.0m behind face of guide rail.
- A The system depicted on this OPSD is a proprietary system and shall be installed according to manufacturer's specifications.
- B Posts and sleeves shall be manufactured from hot rolled carbon sheet steel, structural quality according to ASTM A 653, Grade 50 steel or ASTM A 1011, Grade 50 steel.
- C Posts and sleeves manufactured from ASTM A 653, Grade 50 steel shall be stripped prior to being hot dip galvanized.
- D Posts and sleeves shall be hot dip galvanized after fabrication. Excess zinc shall be removed to ensure telescoping of posts and sleeves.
- E System configuration meets NCHRP Report 350 TL-3.
- F All dimensions are in millimetres unless otherwise shown.

ONTARIO PROVINCIAL STANDARD DRAWING	Apr 2019	Rev 1	
SMALL SIGN SUPPORT SYSTEM SQR-LOC PERFORATED STEEL SQUARE POST SYSTEM INSTALLATION-DOUBLE POST ASSEMBLY			
OPSD 989.210			