

NOTES

1. ALL DUCTS SHALL MEET C.S.A C22.2 #211-2 SPECIFICATIONS OR APPROVED EQUAL.
2. ALL FITTINGS SHALL BE MOLDED OR FABRICATED AND SHALL BE COMPATIBLE WITH DUCT MATERIAL. JOINING METHODS SHALL CONFORM TO MANUFACTURERS RECOMMENDED PRACTICES.
3. HANDHOLE SHALL BE MADE FROM SDR26 PVC PIPE OR DR26 POLYETHYLENE PIPE, 457mm O.D. AND MINIMUM WALL THICKNESS OF 17mm.
4. INTEGRAL BELL ENDS SHALL BE USED ON ALL 50mm AND 75mm DUCTS ENTERING HANDHOLES. INTEGRAL BELL ENDS SHALL BE INSTALLED FLUSH WITH THE INSIDE WALL OF THE HANDHOLE.
5. PRIMARY DUCTS SHALL ENTER THE HANDHOLE AT THE SAME ELEVATION PERPENDICULAR TO THE HANDHOLE WALL AND SHALL BE ALIGNED TO THE CENTER OF THE HANDHOLE.
6. ALL ENTRANCE HOLES INTO HANDHOLES SHALL BE MADE WITH A HOLE SAW WITH DIA. NO MORE THAN 6mm LARGER THAN THE O.D. OF THE DUCT OR FITTING BEING USED.
7. METAL FRAME AND COVER ASSEMBLY SHALL BE ATTACHED TO PVC OR POLYETHYLENE PIPE BY THREE 9mm STAINLESS STEEL BOLTS.
8. GROUND WIRE SHALL BE ATTACHED TO METAL HANDHOLE FRAME USING A GROUND LUG SUITABLE FOR #6 AWG COPPER WIRE.
9. GROUND STRAP SHALL BE ATTACHED TO METAL HANDHOLE FRAME AND COVER USING GROUND LUGS SUITABLE FOR GROUND STRAP TERMINALS.
10. HANDHOLES SHALL BE PLACED IN RAISED MEDIAN ISLANDS SHALL BE LOCATED A MINIMUM OF 2.5 METRES FROM THE BULLNOSE AND CENTERED. SEE REGION OF DURHAM STANDARD DRAWING S-300.070.

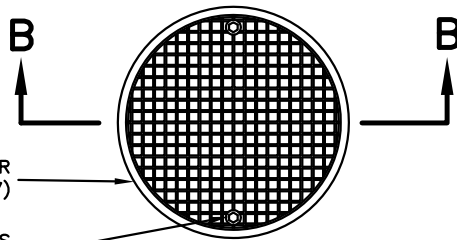

METAL FRAME AND COVER ASSEMBLY (SEE NOTE 7)

STD. THREAD STAINLESS BOLTS WITH 19mm (3/4 in) HEAD

PLAN

MINIMUM OF 3 STANDARD SIZE HOUSING BRICKS FOR FOOTING

13mm WOVEN POLYESTER TAPE (MULE TAPE) FISH LINE IN ALL PRIMARY DUCTS WITH 1.5 METRES COILED AT EACH END (TYP.)

50mm OR 75mm DIA. PRIMARY DUCT (TYP.) (SEE NOTE 5 & 6)

PVC OR POLYETHYLENE PIPE SEE NOTE 3

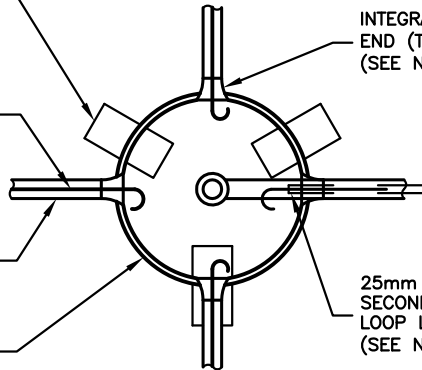

INTEGRAL BELL END (TYP.) (SEE NOTE 4)

25mm OR 32mm DIA. SECONDARY DUCT FOR LOOP LEAD-IN WIRE (SEE NOTE 6)

SECTION A-A

TOP OF HANDHOLE SHALL BE FLUSH WITH FINISHED GRADE UNLESS NOTED OTHERWISE ON CONTRACT DRAWINGS

GROUND LUGS TO BE ATTACHED TO METAL FRAME MOUNTING BOLT SEE NOTE 8 & 9

STEEL GROUND PLATE AS PER S-411.020 WHERE REQUIRED

CONNECTION BY THERMITE WELD OR MECHANICAL CLAMP

90 DEGREE RIGID P.V.C. BEND-TYP. 600mm MIN. RADIUS (SEE NOTE 2)

GROUND LUG SHALL BE WELDED TO METAL HANDHOLE COVER (SEE NOTE 9)

BARE COPPER BRAIDED GROUND STRAP, 300mm IN LENGTH WITH APPROVED TERMINALS (SEE NOTE 9)

FINISHED GRADE

DUCT END SHALL BE CAPPED FLUSH WITH ASPHALT SURFACE UNTIL READY FOR USE

ASPHALT SURFACE

GRANULAR BASE

TERMINATE 25mm OR 32mm DIA. SECONDARY DUCT AT EDGE OF PAVEMENT AS SHOWN

PRIMARY SIGNAL DUCTS CROSSING ROADWAY MAY ENTER FROM BOTTOM OF HANDHOLE

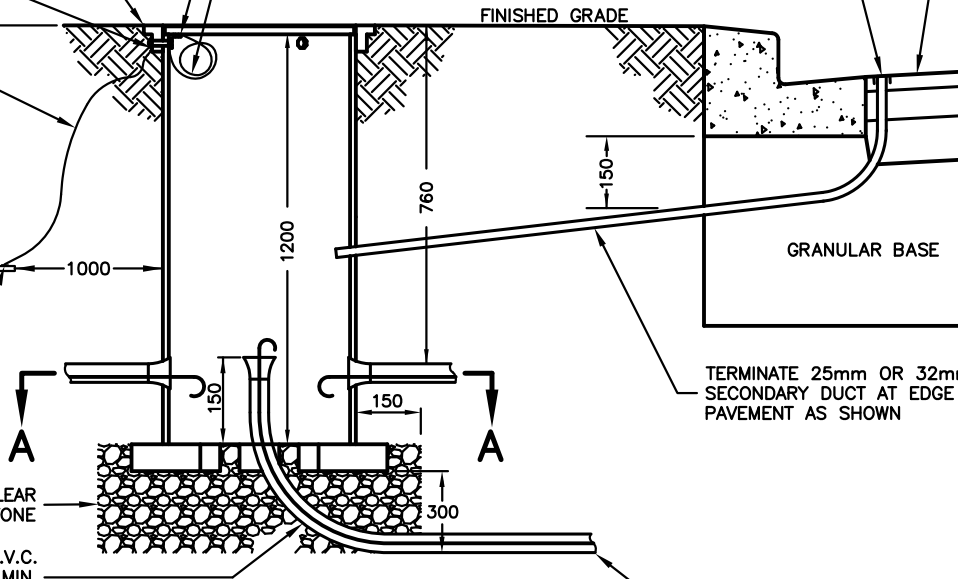

SECTION B-B

ALL DIMENSIONS IN MILLIMETERS EXCEPT WHERE NOTED.



WORKS DEPARTMENT

ELECTRICAL HANDHOLE WITH COVER NON CONCRETE 450 mm DIA.

DWG. DATE: 1980 06

REVISION NO.: 17

REV. DATE: 2013 04

SCALE: N.T.S.

S-400.030