

CROSS SECTION

CAST-IN-PLACE BASE

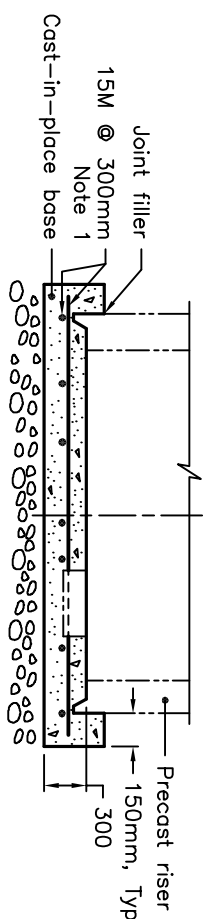
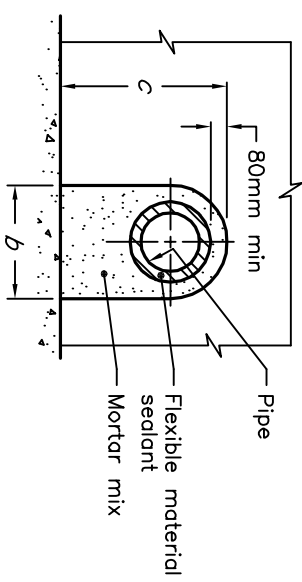

WALL OPENING DETAIL

SECTION A-A

- NOTES:**
- 1 Sump shall be placed to avoid associated appurtenances and step landing. Position steel reinforcement to maintain minimum 50mm cover at sump.
 - A This OPSPD shall be read in conjunction with OPSPD 701.030, 701.031, 701.032, 701.041, and 703.011.
 - B Bond breaker shall be used between the concrete and the fittings and appurtenances.
 - C All dimensions are in millimetres unless otherwise shown.

Dimension	Pipe diameter	
	100 to 250mm	300 to 350mm
a	Ø1200	Ø1500
b	400	550
c	600	750

ONTARIO PROVINCIAL STANDARD DRAWING

Nov 2015 Rev 4

PRECAST VALVE CHAMBER

1200mm AND 1500mm DIAMETER

OPSPD 1101.010

